

MODEL XGQT2 FLEXIBLE COUPLING



The Lede Model XGQT2 is a standard flexible coupling for use in a variety of general piping applications of moderate pressure services. The Model XGQT2 couplings features flexibility that can deal with misalignment, distortion, thermal stress, vibration and noise and also resist seismic tremors. With the use of Model XGQT2 couplings you can even design a curved layout.

SPECIFICATIONS

Sizes available:

25 mm - 600 mm / 1" ~ 24"

Working Pressure:

Up to 20 bar / 300 psi

Maximum working pressures are CWP (cold water pressure) or maximum allowed working pressure within the service temperature range of the gasket used in the coupling, based on standard wall or sch. 7/10/40 steel pipe, cut or roll-grooved to ANSI/AWWA C606-04 specifications.

These ratings may occasionally differ from maximum working pressures listed and/or approved by UL, ULC, and/or FM as testing conditions and test pipes differ. For performance data on other pipe schedules contact Lede.

Housing Coating:

Red Enamel

Housing material:

Ductile Iron conforming to ASTM A536 Gr. 65-45-12.

Gasket material:

EPDM (Silicon free) These gaskets have excellent self sealing capabilities and are designed to provide a leak tight seal.



INSTALLATION



LEDE GROOVED PIPING SYSTEM

The Lede grooved piping system is one of the most advanced, versatile, economical and reliable systems available today. After the pipe ends are grooved a gasket is stretched over the pipe ends. The coupling segments are then placed over the gasket and the bolts and nuts are fastened resulting in a secure and leak free joint.

INTERNATIONAL APPROVAL



SUBMITTAL INFORMATION

PROJECT:	CONTRACTOR:	DATE:
ENGINEER:	SPECIFICATION REFERENCE:	SYSTEM TYPE:
LOCATIONS:	COMMENTS:	

DATA CHART

Lede couplings are identified by the nominal IPS pipe size in inches or nominal diameter of pipe (DN) in millimeters.

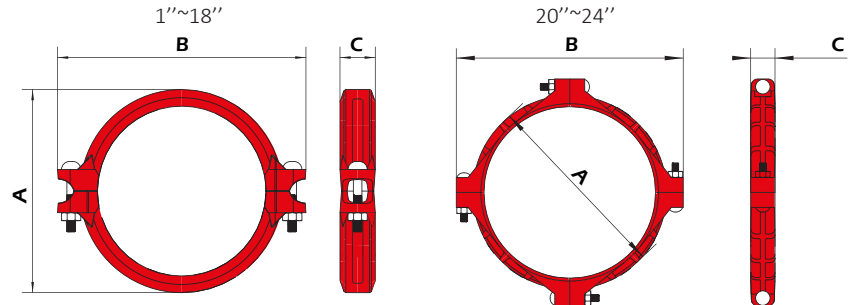

Nominal Size mm/in	Actual O.D. mm/in	Max. Working Pressure Bar/PSI	Max. End Load KN/Lbs	Axial Displacement mm/in	Angular Movement		Dimensions			Bolt Size mm/in
					Per Coupling Degree (°)	Per Pipe in/ft	A mm/in	B mm/in	C mm/in	
25	33.7	20	1.80	1.6		0.58	55	97	45	M10x40
1	1.327	300	405	0.0625	2°-45'	48	2.17	3.82	1.77	3/8x1-1/2
32	42.4	20	2.92	1.6		0.46	63.5	107.5	45	M10x45
1 1/4	1.669	300	656	0.0625	2°-10'	38	2.50	4.23	1.77	3/8x1-3/4
40	48.3	20	3.79	1.6		0.4	69	114	45	M10x45
1 1/2	1.9	300	852	0.0625	1°-54'	33	2.72	4.49	1.77	3/8x1-3/4
50	60.3	20	5.91	1.6		0.32	83.6	124	46	M10x55
2	2.375	300	1327	0.0625	1°-31'	27	3.29	4.88	1.81	3/8x2-1/8
65	73	20	8.66	1.6		0.26	98	137	46	M10x55
2 1/2	2.875	300	1945	0.0625	1°-15'	22	3.86	5.39	1.81	3/8x2-1/8
80	88.9	20	12.84	1.6		0.22	114	156	46	M10x55
3	3.5	300	2885	0.0625	1°-02'	18	4.49	6.14	1.81	3/8x2-1/8
100	108	20	18.94	3.2		0.36	138	186	50	M12x65
4	4.25	300	4258	0.125	1°-42'	30	5.43	7.32	1.97	1/2x2-5/8
125	141.3	20	32.43	3.2		0.27	170	218	50	M12x65
5	5.563	300	7288	0.125	1°-18'	23	6.69	8.58	1.97	1/2x2-5/8
150	168.3	20	46.00	3.2		0.23	198	251	50	M12x65
6	6.625	300	10340	0.125	1°-05'	19	7.80	9.88	1.97	1/2x2-5/8
200	219.1	20	77.97	3.2		0.18	256	316	60	M16x80
8	8.625	300	17524	0.125	0°-50'	15	10.08	12.44	2.36	5/8x3-1/8
250	273.0	20	121.05	3.2		0.14	319	393	64	M20x90
10	10.75	300	27206	0.125	0°-50'	12	12.56	15.47	2.52	3/4x3-1/2
300	323.9	20	170.39	3.2		0.12	374	453	65	M20x110
12	12.75	300	38297	0.125	0°-50'	10	14.72	17.83	2.56	3/4x4-1/3
350	355.6	20	198.53	3.2		0.06	410	510	75	M22x110
14	14	300	46150	0.125	0°-31'	4.5	16.14	20.08	2.95	7/8x4-1/3
400	406.4	20	259.30	3.2		0.05	459	555	75	M22x140
16	16	300	60280	0.125	0°-27'	4	18.07	21.85	2.95	7/8x5-1/2
450	457.2	20	327.89	3.2		0.04	516	606	78	M22x140
18	18	300	76300	0.125	0°-24'	3.5	20.31	23.86	3.07	7/8x5-1/2
500	508.0	20	490.60	3.2		0.04	567	674	78	M22x140
20	20	300	113980	0.125	0°-19'	3	22.32	26.54	3.07	7/8x5-1/2
550	558.8	20	584.20	3.2		0.03	622	728	78	M22x140
22	22	300	135640	0.125	0°-18'	2.5	24.49	28.66	3.07	7/8x5-1/2
600	609.6	20	684.72	3.2		0.03	674	778	78	M24x150
24	24	300	159190	0.125	0°-17'	2.5	26.54	30.63	3.07	1x5-9/10

Deflection or angular movement is the maximum value that a coupling allows under no internal pressure.

Weights:

All weights are approximate and subject to change without notice.

Lede reserves the right to change or modify product designs, specifications and/or standard equipment without notice and without incurring obligation.

Sales:

Prices and Terms and Conditions of Sale are subject to change without notice.

Warranty:

We warrant all Lede products to be free from defects in materials and workmanship under normal conditions of use and service. For more information please contact LEDE.