

# Sanicom<sup>®</sup> 2

## aguas grises, aguas salinas

SANICOM 2 es una potente estación de bombeo para aguas grises con doble motor funcionando en alternancia. Aguanta las aguas calientes y jabonosas de locales comerciales y caudales de hasta 16,5 m<sup>3</sup>/h. Procura un servicio constante gracias a sus sistemas de alarma opcionales y doble motor.



### RENDIMIENTO

- HMT máx. 15 m
- Caudal máx 16 m<sup>3</sup>/h

### VENTAJAS

- Aguanta las aguas muy calientes, hasta 90°C (no continuo).
- Eleva las aguas hasta 11 metros en vertical.
- Turbina con paso libre de 8 mm.
- Ideal para locales comerciales exigentes.
- Se instala directamente al suelo.

### MEDIDAS

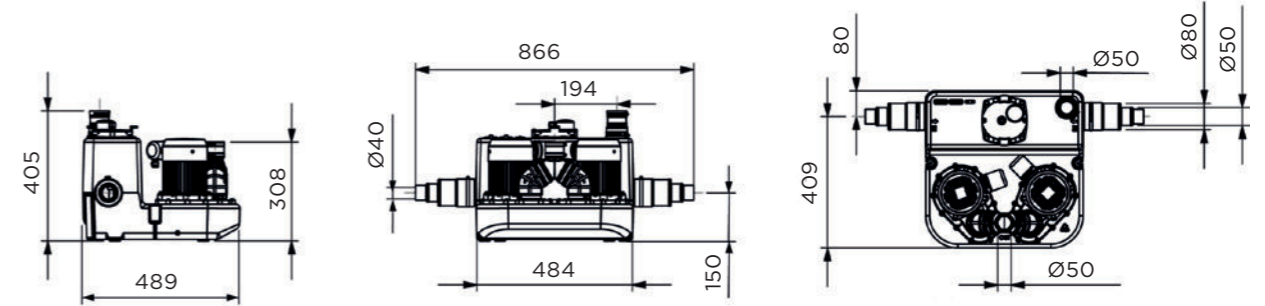

### CURVA

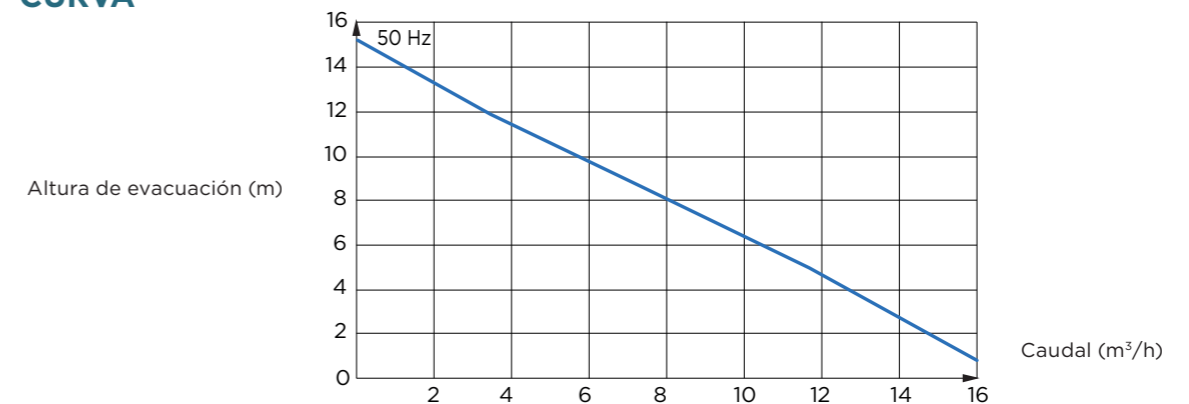

Accede a toda la información técnica del producto

### DE SERIE

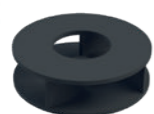

Turbina de doble disco



Bloque electrónico deportado

### OPCIONAL

Alarma con cable



Llaves de corte y filtro



Ver accesorios pág. 126

### CONEXIONES

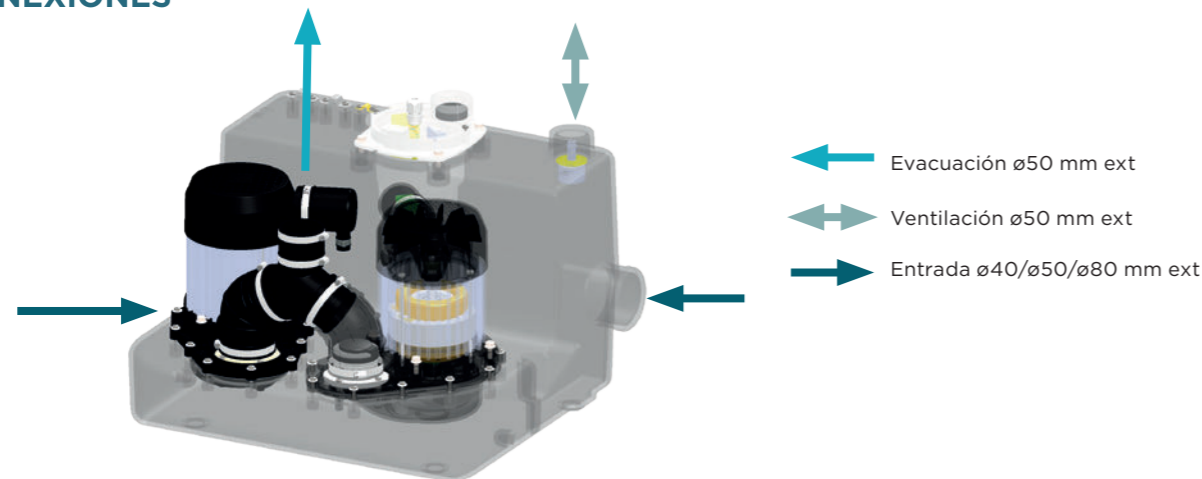

	SANICOM 2
Tipo de cuadro de control	estándar
<b>Materiales</b>	
Depósito	PE
Cuerpo de la bomba	PA 12 GF
Cuerpo motor	Aluminio
Turbina	PA 6 GF
<b>Características eléctricas</b>	
Voltaje (V)	230
Frecuencia (Hz)	50-60
Potencia absorbida P1 (W)	1500
Potencia motor P2 (W)	1050
Índice de protección	IPX4
<b>Hidráulica</b>	
HMT máx. (m)	15
Caudal máximo (m <sup>3</sup> /h)	16
Diámetro ext. de entrada (mm)	40, 50, 80
Diámetro ext. de evacuación (mm)	50
Diámetro ext. de ventilación (mm)	50
Volumen total (L)	34
Volumen útil (L)	13
Nivel ON/Nivel OFF (mm)	145/60
Nivel de alarma (mm)	215
Paso de sólidos (mm)	8
Temperatura máxima del líquido bombeado (5 min)	90°C
Tipo de turbina	doble disco
Tipo de detección	neumático
<b>Logística</b>	
Peso bruto (kg)	26
Código EAN	3308815082868
Referencia	04COM2M
PVP (sin IVA)	1.970 €

**SANICOM 2**  
1292 | 02.20

# SFA



**\*option**



**SANICOM2®**

**FR** NOTICE D'INSTALLATION

**UK** INSTALLATION INSTRUCTIONS

**DE** INSTALLATIONSHINWEISE

**IT** STRUZIONI PER L'INSTALLAZIONE

**ES** MANUAL DE INSTALACIÓN

**PT** MANUAL DE INSTALAÇÃO

**NL** INSTALLATIE VOORSCHRIFTEN

**SE** INSTALLATIONSANVISNING

**DK** INSTALLATIONSVEJLEDNING

**NO** INSTALLASJONSANVISNING

**FI** ASENNUSOHJEET

**HU** FELSZERELÉSI ÉS KEZELÉSI ÚTMUTATÓ

**PL** INSTRUKCJA INSTALACJI

**RU** ИНСТРУКЦИЯ ПО МОНТАЖУ И ЭКСПЛУАТАЦИИ

**RO** MANUAL DE INSTALARE

**CZ** NÁVOD K INSTALACI A POUŽÍVÁNÍ

**TR** KURULUM KILAVUZU

**EL** ΟΔΗΓΙΕΣ ΕΓΚΑΤΑΣΤΑΣΗΣ

**CN** 指南以备用

**KR** 설치내용서

**CE**



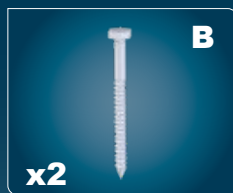
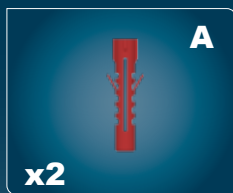
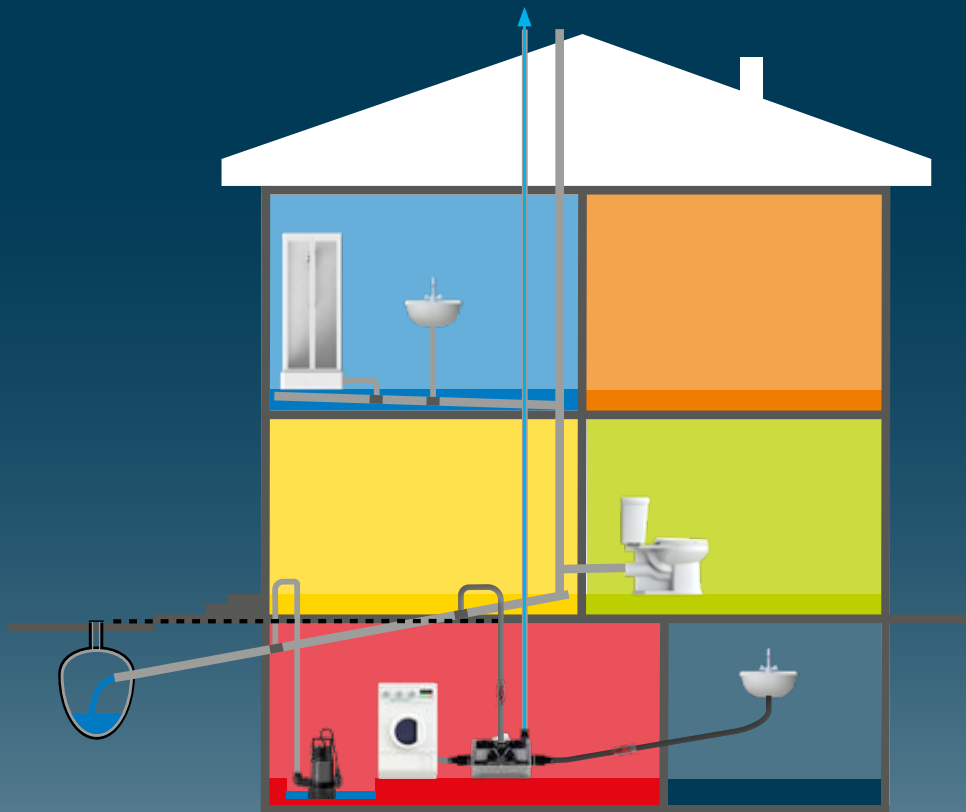

**1**



**2**



3

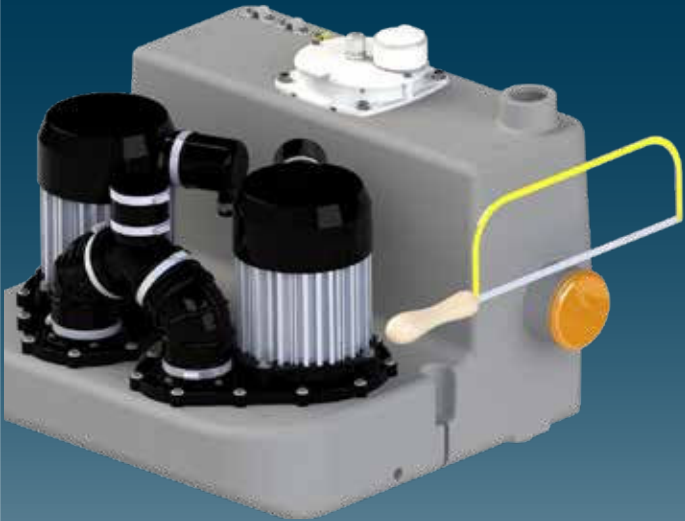

4

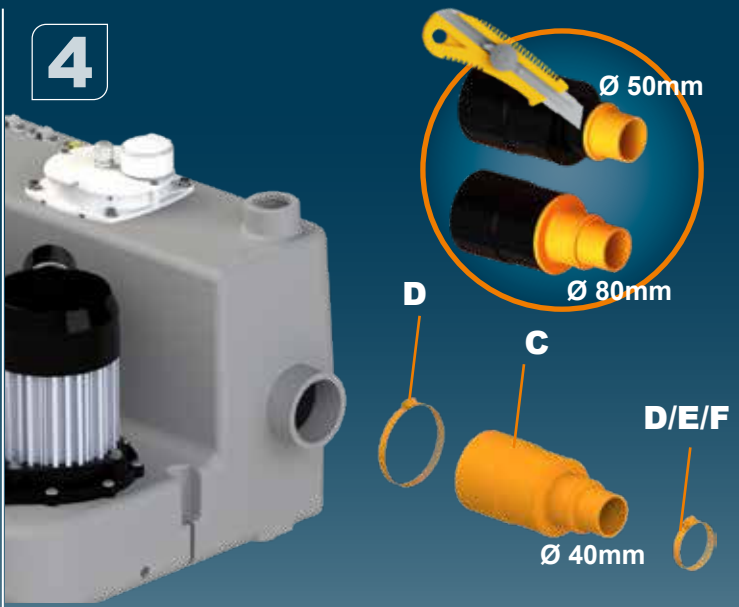

Ø 40/50/80mm Ext

5



6

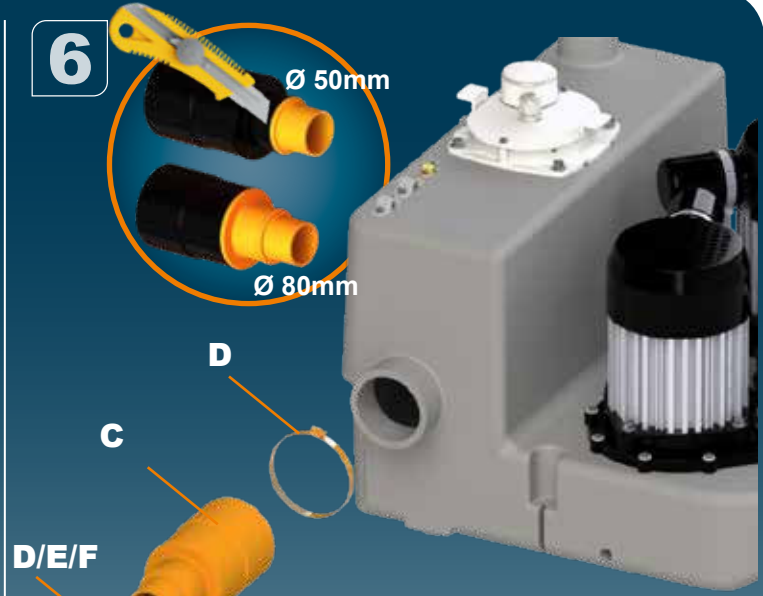

Ø 40/50/80mm Ext

7

Ø 50mm Ext

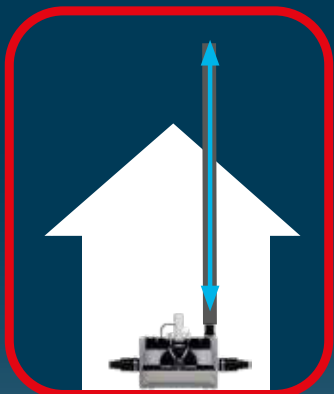
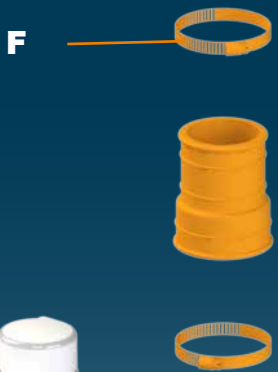

8

Ø 50mm Ext



9

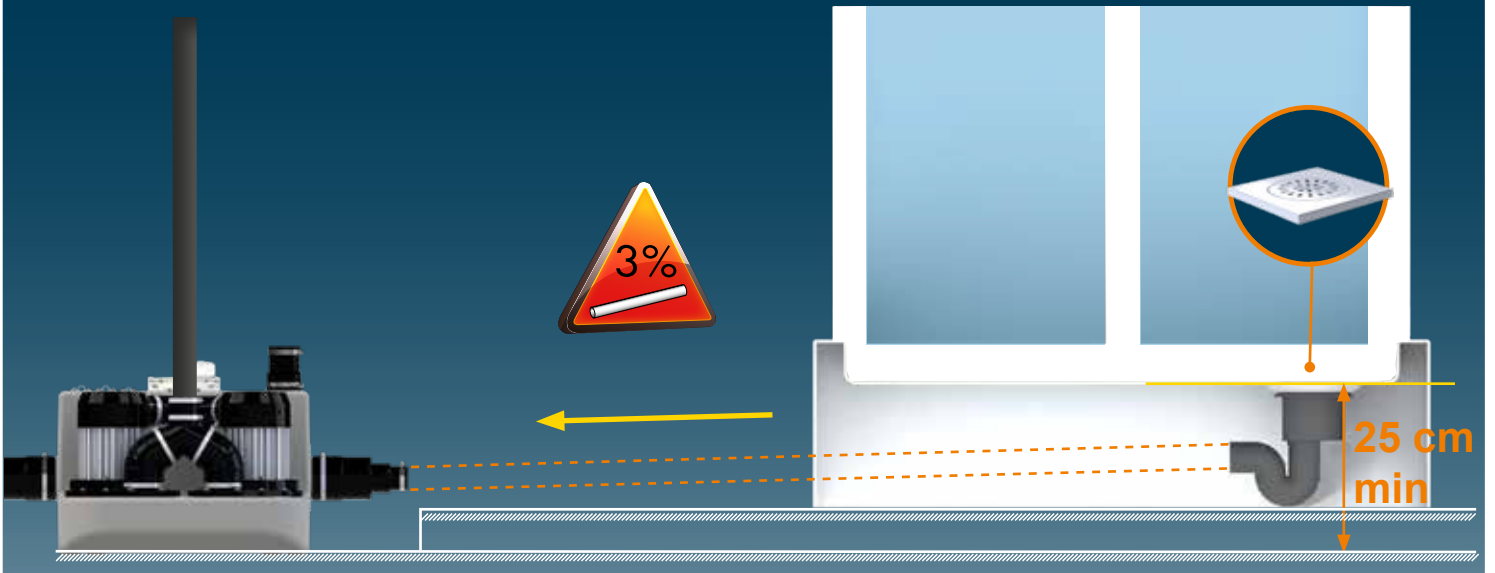

10

H

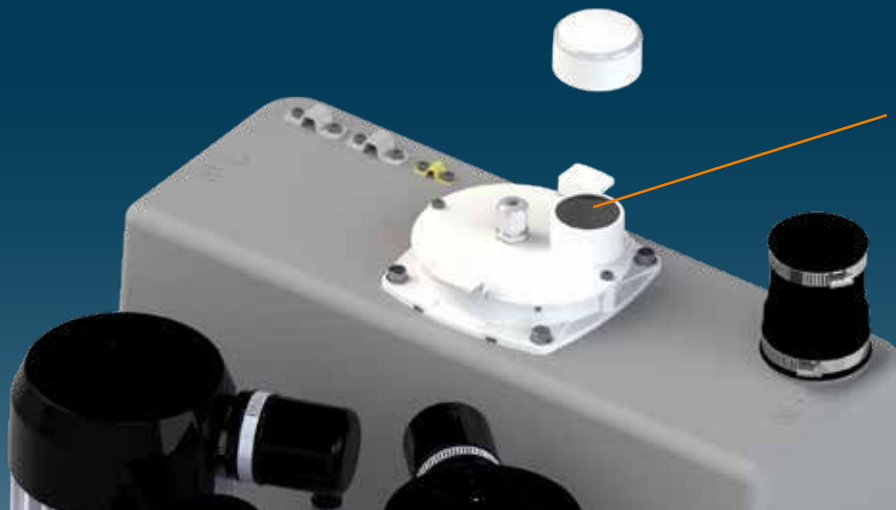

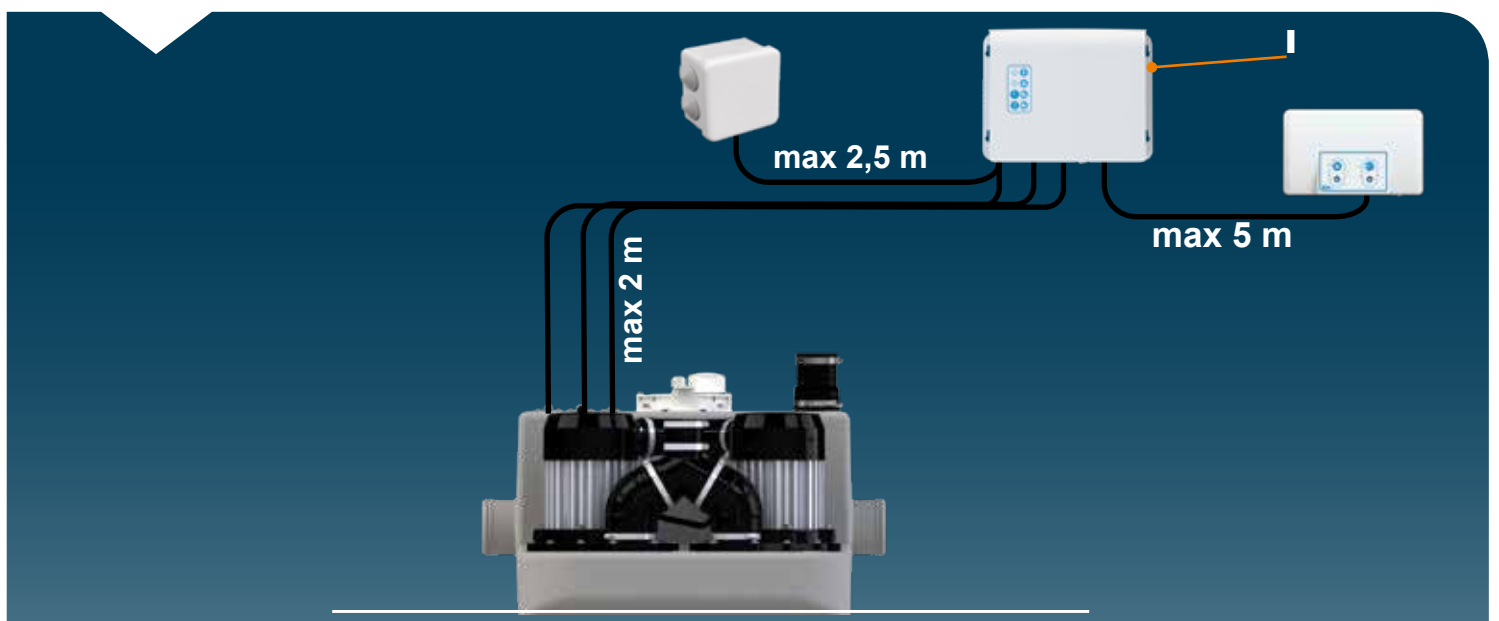
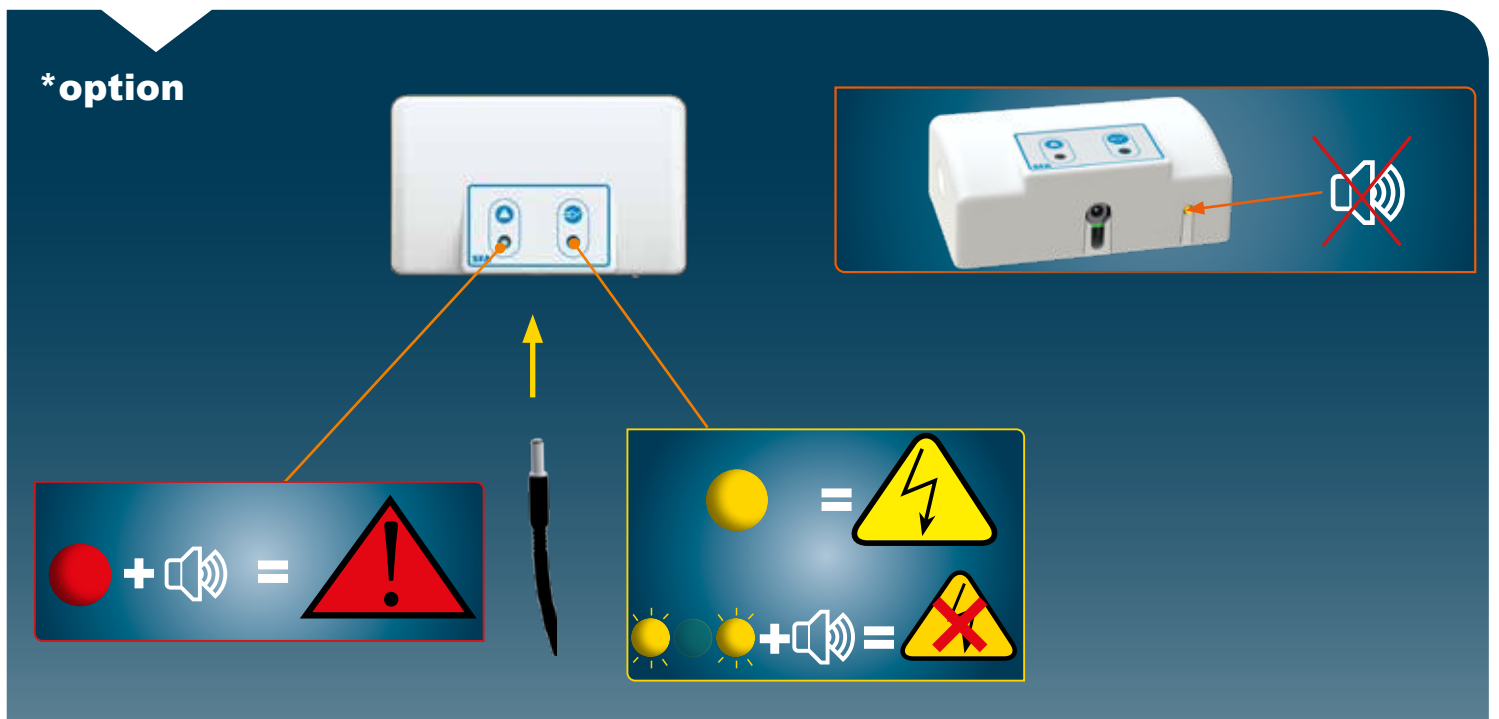
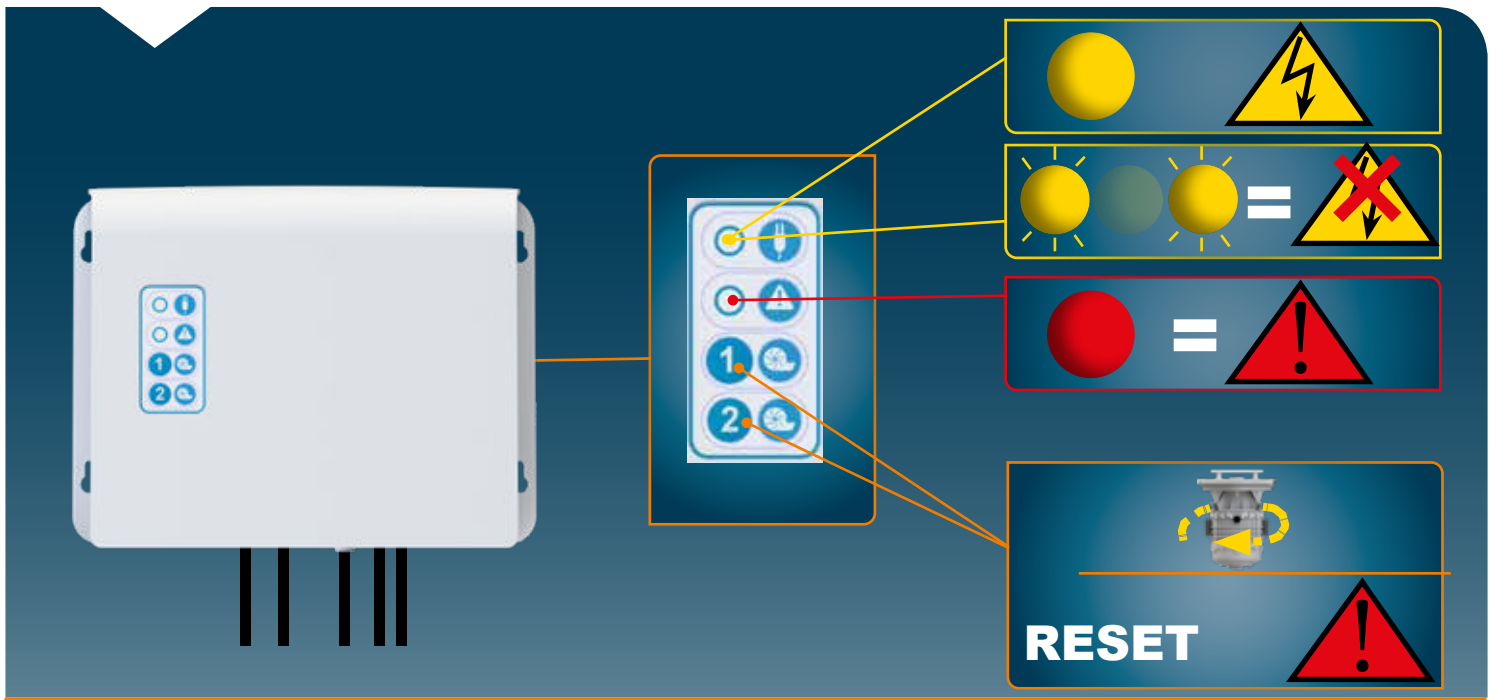

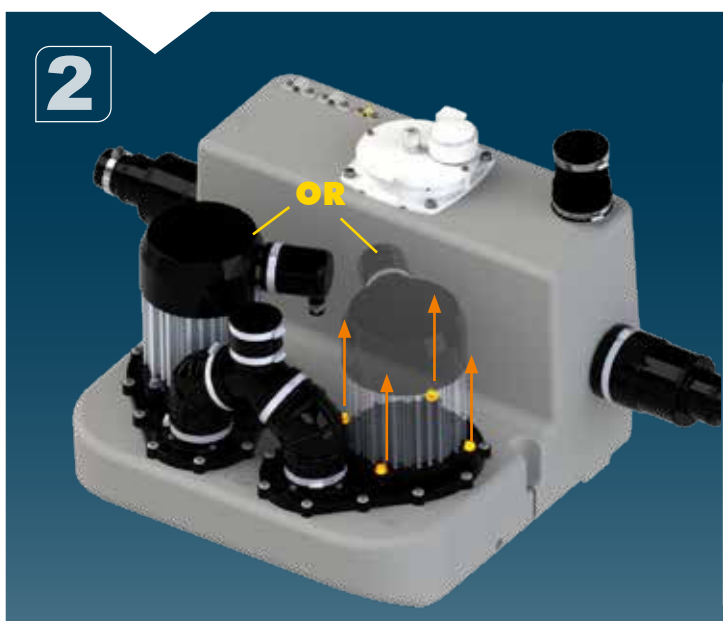

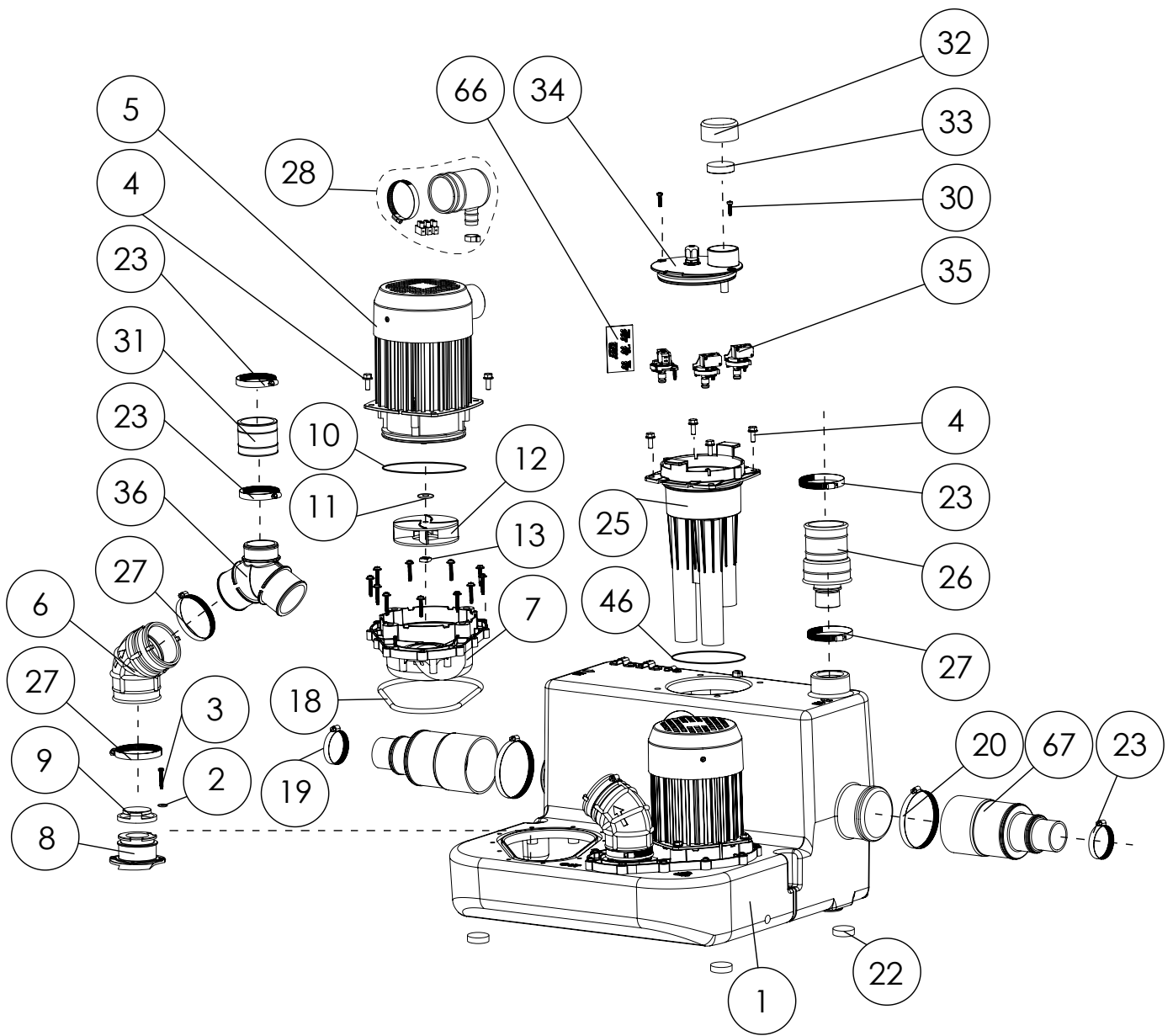
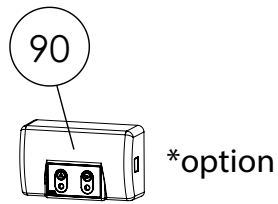
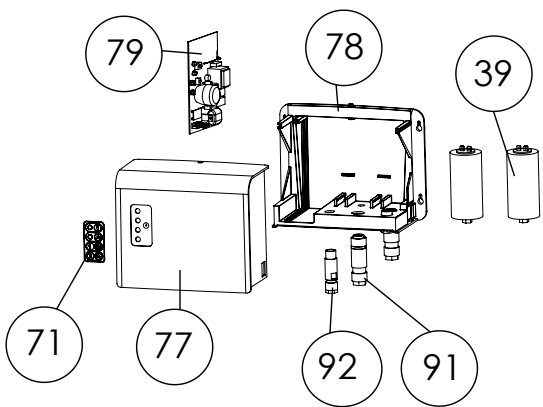

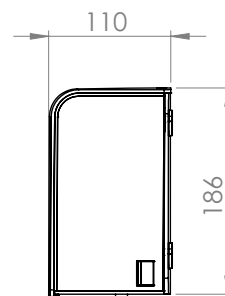
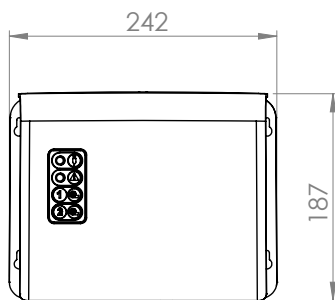
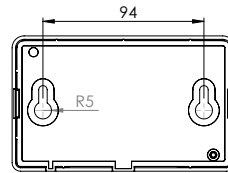
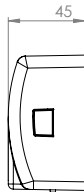
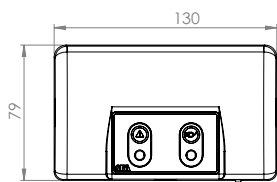
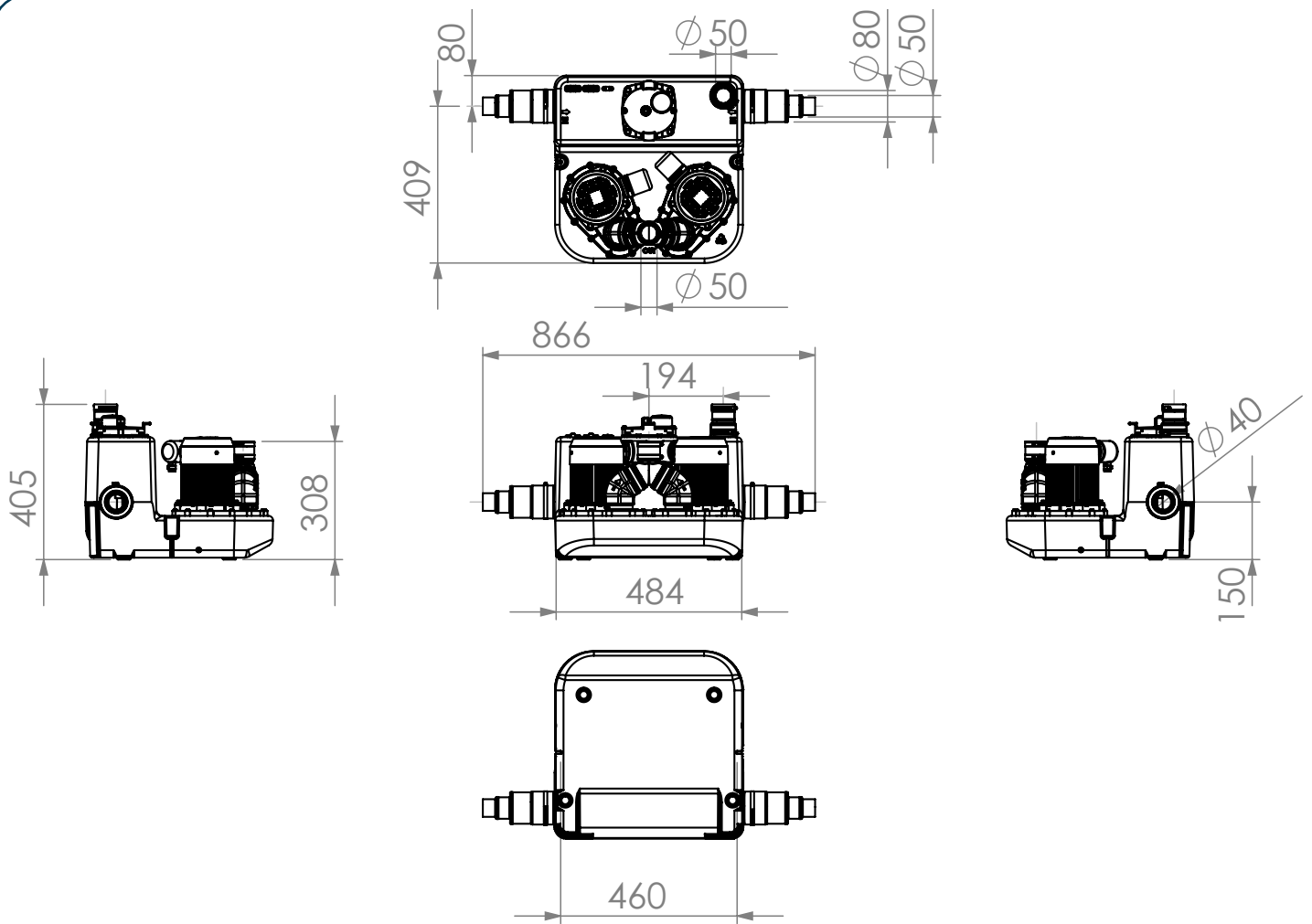

**SANICOM2**  
**220-240 V - 50-60 Hz**  
**3000W CLASS 1**  
**26 Kg**  
**Max temperature:**  
**90°C for 5Min**

**H(m)**

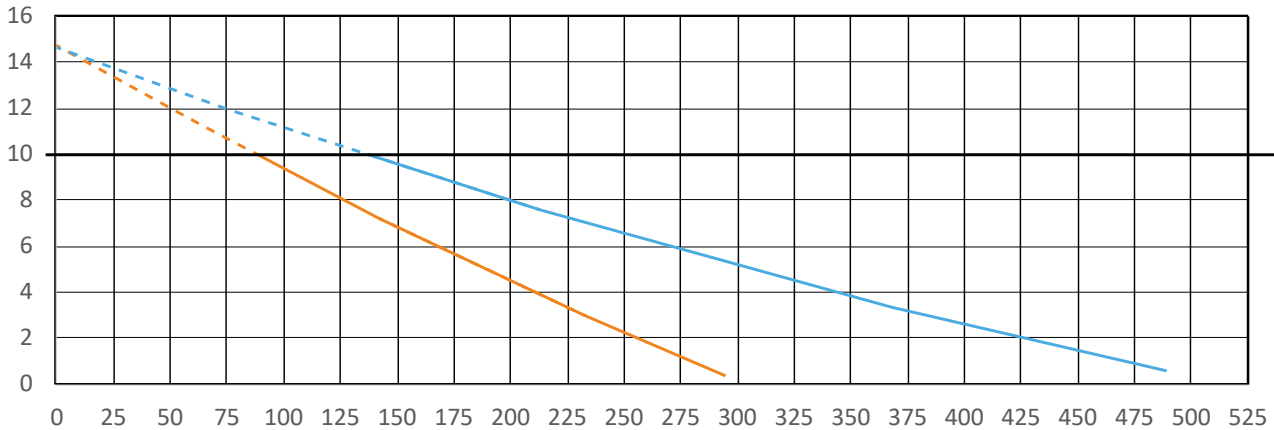

**Q (L/min)**

— Moteur 1 — Moteurs 1+2

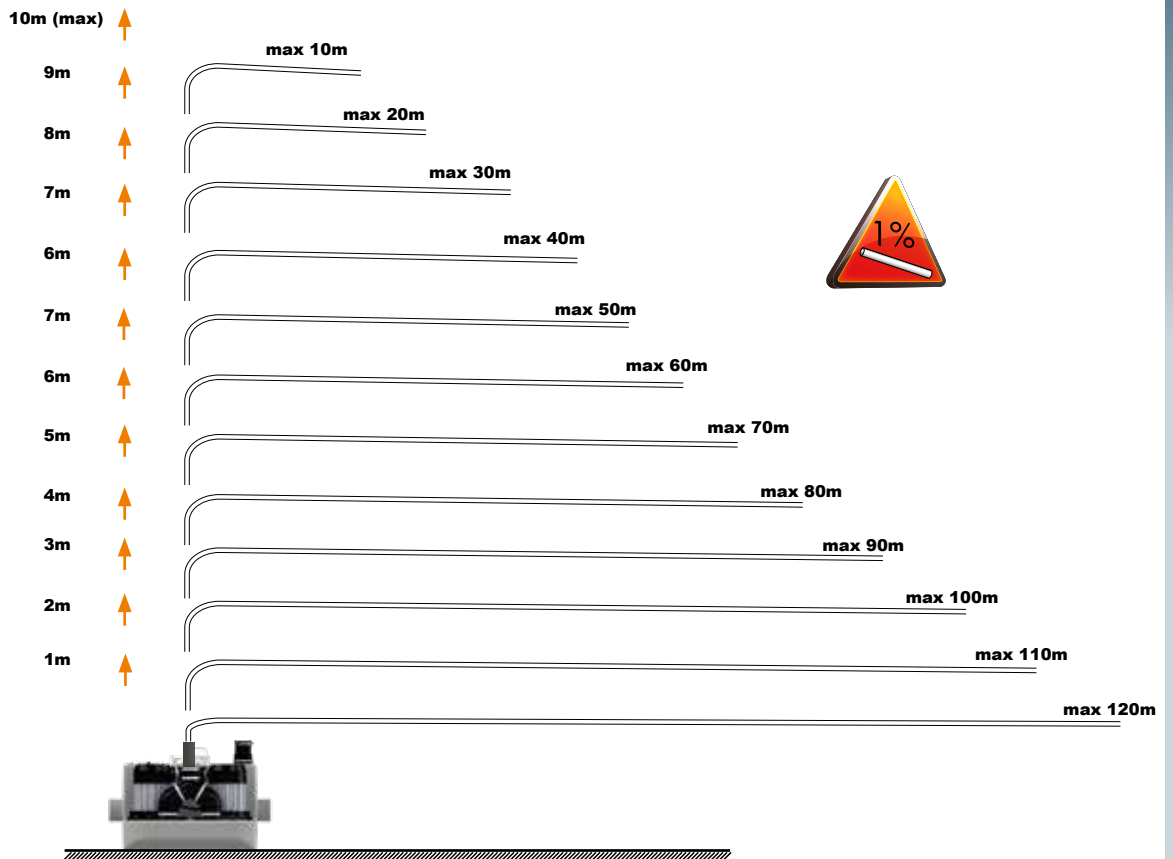

**SERVICE HELPLINES**

**France**  
Tel. 01 44 82 25 55  
Fax. 03 44 94 46 19

**United Kingdom**  
Tel. 08457 650011 (Call from a land line)  
Fax. 020 8842 1671

**Ireland**  
Tel. 1850 23 24 25 (LOW CALL)  
Fax. +353 46 97 33 093

**Australia**  
Tel. +1300 554 779  
Fax. +61.2.9882.6950

**Deutschland**  
Tel. 0800 82 27 82 0  
Fax. (060 74) 30928-90

**Italia**  
Tel. 0382 6181  
Fax. +39 0382 618200

**España**  
Tel. +34 93 544 60 76  
Fax. +34 93 462 18 96

**Portugal**  
Tel. +35 21 911 27 85  
Fax. +35 21 957 70 00

**Suisse Schweiz Svizzera**  
Tel. +41 (0)32 631 04 74  
Fax. +41 (0)32 631 04 75

**Benelux**  
Tel. +31 475 487100  
Fax. +31 475 486515

**Sverige**  
Tel. +08-404 15 30

**Norge**  
Tel. +08-404 15 30

**Polska**  
Tel. (+4822) 732 00 33  
Fax. (+4822) 751 35 16

**РОССИЯ**  
Tel. (495) 258 29 51  
Fax. (495) 258 29 51

**Česká Republika**  
Tel. +420 266 712 855  
Fax. +420 266 712 856

**România**  
Tel. +40 724 364 543  
service@saniflo.ro

**Türkiye**  
Tel. +90 212 275 30 88  
Fax. +90 212 275 90 58

**Brazil**  
Tel. (11) 3052-2292

中国  
Tel. +86(0)21 6218 8969  
Fax. +86(0)21 6218 8970

**South Africa**  
Tel. +27 (0) 21 286 00 28

Service information : [www.sfa.biz](http://www.sfa.biz)